

PNP SILICON PLANAR EPITAXIAL TRANSISTORS

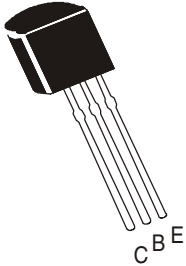

**BC556, A, B,
BC557, A, B, C
BC558, A, B, C**

**TO-92
Plastic Package**
For Lead Free Parts, Device
Part # will be Prefixed with
"T"

Amplifier Transistors

ABSOLUTE MAXIMUM RATINGS ($T_a=25^\circ\text{C}$)

DESCRIPTION	SYMBOL	BC556	BC557	BC558	UNITS
Collector Emitter Voltage	V_{CEO}	65	45	30	V
Collector Emitter Voltage	V_{CES}	80	50	30	V
Collector Base Voltage	V_{CBO}	80	50	30	V
Emitter Base Voltage	V_{EBO}	5			V
Collector Current Continuous	I_C	100			mA
Collector Current Peak	I_{CM}	200			mA
Base Current Peak	I_{BM}	200			mA
Emitter Current Peak	I_{EM}	200			mA
Power Dissipation at $T_a=25^\circ\text{C}$	P_D	500			mW
Derate Above 25°C		4.0			mW/ $^\circ\text{C}$
Storage Temperature	T_{stg}	- 65 to +150			$^\circ\text{C}$
Junction Temperature	T_j	150			$^\circ\text{C}$

THERMAL RESISTANCE

Junction to Ambient in free air	$R_{th(j-a)}$	250	$^\circ\text{C}/\text{W}$
---------------------------------	---------------	-----	---------------------------

ELECTRICAL CHARACTERISTICS ($T_a=25^\circ\text{C}$ unless specified otherwise)

DESCRIPTION	SYMBOL	TEST CONDITION	BC556	BC557	BC558	UNITS
Collector Emitter Voltage	V_{CEO}	$I_C=2\text{mA}, I_B=0$	>65	>45	>30	V
Collector Base Voltage	V_{CBO}	$I_C=100\mu\text{A}, I_E=0$	>80	>50	>30	V
Emitter Base Voltage	V_{EBO}	$I_E=100\mu\text{A}, I_C=0$	>5.0			V
Collector Cut Off Current	I_{CBO}	$V_{CB}=30\text{V}, I_E=0$ ALL $V_{CB}=30\text{V}, I_E=0, T_j=150^\circ\text{C}$ ALL	<15		<5.0	nA μA
Collector Cut Off Current	I_{CES}	$V_{CE}=80\text{V}, V_{BE}=0$ $V_{CE}=50\text{V}, V_{BE}=0$ $V_{CE}=30\text{V}, V_{BE}=0$ $V_{CE}=80\text{V}, V_{EB}=0, T_j=125^\circ\text{C}$ $V_{CE}=50\text{V}, V_{EB}=0, T_j=125^\circ\text{C}$ $V_{CE}=30\text{V}, V_{EB}=0, T_j=125^\circ\text{C}$	<15 <4.0	<15 <4.0	<15 <4.0	nA nA nA μA μA μA

PNP SILICON PLANAR EPITAXIAL TRANSISTORS

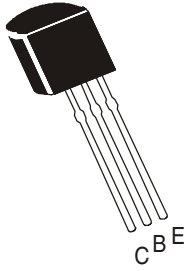

**BC556, A, B,
BC557, A, B, C
BC558, A, B, C**

**TO-92
Plastic Package**
For Lead Free Parts, Device
Part # will be Prefixed with
"T"

ELECTRICAL CHARACTERISTICS (T_a=25°C unless specified otherwise)

DESCRIPTION	SYMBOL	TEST CONDITION	MIN	TYP	MAX	UNITS	
DC Current Gain	h _{FE}	I _C =10μA, V _{CE} =5V					
		A		90			
		B		150			
		C		270			
		I _C =2mA, V _{CE} =5V					
		BC556	75		475		
		BC557/558	75		800		
		A	110		220		
		B	200		450		
		C	420		800		
Collector Emitter Saturation Voltage	V _{CE (sat)}	I _C =10mA, I _B =0.5mA			0.30	V	
		I _C =100mA, I _B =5mA			0.65	V	
Base Emitter Saturation Voltage	V _{BE (sat)}	I _C =10mA, I _B =0.5mA		0.7		V	
		I _C =100mA, I _B =5mA		0.9		V	
Base Emitter On Voltage	V _{BE (on)}	I _C =2mA, V _{CE} =5V	0.55		0.70	V	
		I _C =10mA, V _{CE} =5V			0.82	V	

SMALL SIGNAL CHARACTERISTICS

DESCRIPTION	SYMBOL	TEST CONDITION	MIN	TYP	MAX	UNITS	
Transistors Frequency	f _T	I _C =10mA, V _{CE} =5V, f=100MHz		150		MHz	
Collector Output Capacitance	C _{cb0}	V _{CB} =10V, f=1MHz			6.0	pF	
Emitter Input Capacitance	C _{ib}	V _{EB} =0.5V, f=1MHz		9.0		pF	
Noise Figure	NF	I _C =0.2mA, V _{CE} =5V, R _S =2 kΩ, f=1KHz, B=200Hz			10	dB	
Small Signal Current	h _{fe}	I _C =2mA, V _{CE} =5V, f=1KHz					
			A		220		
			B		330		
			C		600		
Input Impedance	h _{ie}	I _C =2mA, V _{CE} =5V, f=1KHz					
			A	1.6		4.5	kΩ
			B	3.2		8.5	kΩ
			C	6.0		15	kΩ
Voltage Feedback Ratio	h _{re}	I _C =2mA, V _{CE} =5V, f=1KHz					
			A		1.5		x10 ⁻⁴
			B		2.0		x10 ⁻⁴
			C		3.0		x10 ⁻⁴
Out Put Admittance	h _{oe}	I _C =2mA, V _{CE} =5V, f=1KHz					
			A			30	umhos
			B			60	umhos
			C			110	umhos

BC556, A, B,
BC557, A, B, C
BC558, A, B, C

TO-92
Plastic Package
For Lead Free Parts, Device
Part # will be Prefixed with
"T"

TO-92 Plastic Package

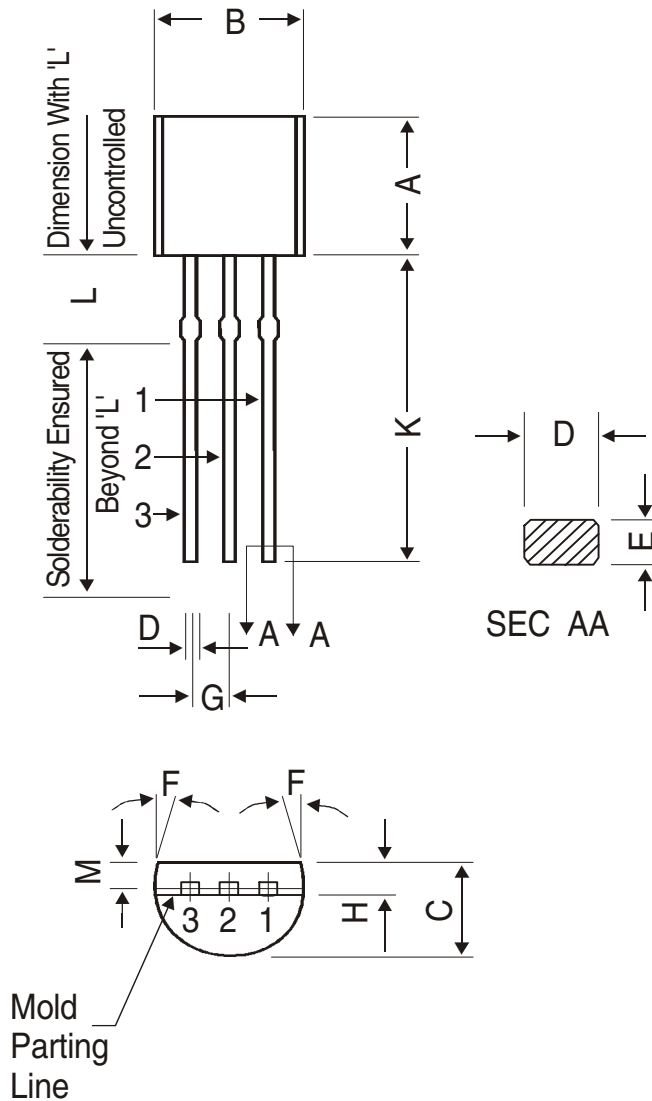

DIM	MIN.	MAX.
A	4.32	5.33
B	4.45	5.20
C	3.18	4.19
D	0.41	0.55
E	0.35	0.50
F	5 DEG	
G	1.14	1.40
H	1.20	1.40
K	12.70	—
L	1.982	2.082
M	1.03	1.20

All dimensions are in mm

PIN CONFIGURATION
1. EMITTER
2. BASE
3. COLLECTOR

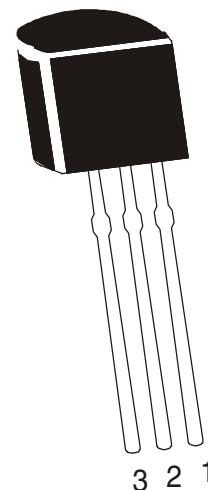

The TO-92 Package, Tape and Ammo Pack drawings are correct as on the date of issue/revision of this Data Sheet.

The currently valid dimensions and information, may please be confirmed from the TO-92 Drawing in the Packages and Packing Section of the Product Catalogue.

Packing Details

PACKAGE	STANDARD PACK		INNER CARTON BOX		OUTER CARTON BOX		
	Details	Net Weight/ Qty	Size	Qty	Size	Qty	Gr Wt
TO-92 Bulk	1K/polybag	200 gm/1K pcs	3" x 7.5" x 7.5"	5K	17" x 15" x 13.5"	80K	23 kgs
TO-92 T&A	2K/ammo box	645 gm/2K pcs	12.5" x 8" x 1.8"	2K	17" x 15" x 13.5"	32K	12.5 kgs

TO-92
Plastic Package
For Lead Free Parts, Device
Part # will be Prefixed with
"T"

TO-92 Tape and Ammo Pack

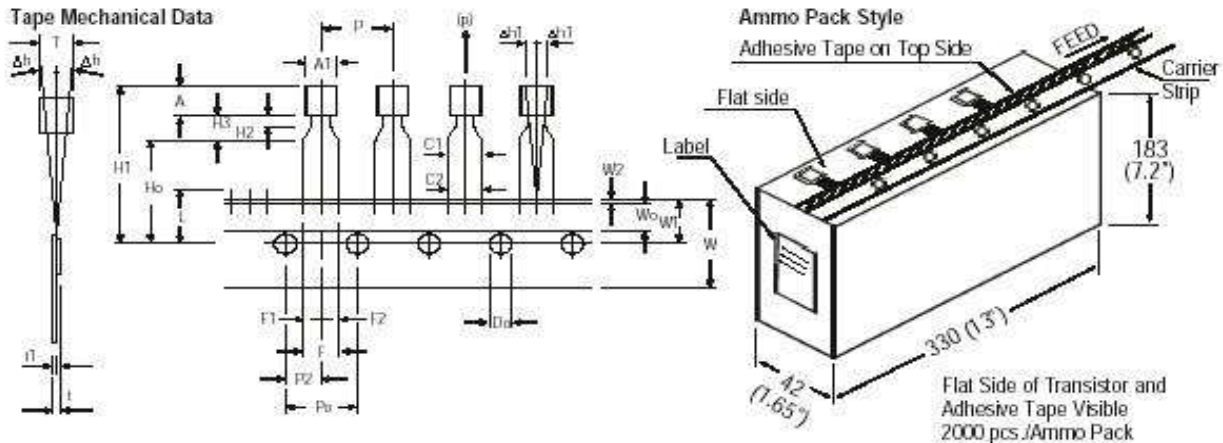

All dimensions are in mm

ITEM	SYMBOL	SPECIFICATION			
		MIN.	NOM.	MAX.	TOL.
BODY WIDTH	A1	4.45		5.20	
BODY HEIGHT	A	4.32		5.33	
BODY THICKNESS	T	3.18		4.19	
PITCH OF COMPONENT	P		12.7		± 1.0
*1 FEED HOLE PITCH	Po		12.7		± 0.3
*2 FEED HOLE CENTRE TO COMPONENT CENTRE	P2		6.35		± 0.4
DISTANCE BETWEEN OUTER LEADS	F		5.08		+0.6 -0.2
*3 COMPONENT ALIGNMENT SIDE VIEW	Δh		0	1.0	
*4 COMPONENT ALIGNMENT FRONT VIEW	Δh1		0	1.3	
TAPE WIDTH	W		18		± 0.5
HOLD-DOWN TAPE WIDTH	W0		6		± 0.2
HOLE POSITION	W1		9		+0.7 -0.5
HOLD-DOWN TAPE POSITION	W2	0.0		0.7	
LEAD WIRE CLINCH HEIGHT	Ho		16		± 0.5
COMPONENT HEIGHT	H1			24.0	
LENGTH OF SNIPPED LEADS	L			11.0	
FEED HOLE DIAMETER	Do		4		± 0.2
*5 TOTAL TAPE THICKNESS	t			1.2	
LEAD - TO - LEAD DISTANCE	F1, F2	2.40		2.70	- 0.1
STAND OFF	H2	0.45		1.45	
CLINCH HEIGHT	H3			3.0	
LEAD PARALLELISM	C1 - C2			0.22	
PULL - OUT FORCE	(p)	6N			

NOTES

1. Maximum alignment deviation between leads will not to be greater than 0.2mm.
2. Maximum non-cumulative variation between tape feed holes shall not exceed 1 mm in 20 pitches.
3. Holddown tape will not exceed beyond the edge(s) of carrier tape and there shall be no exposure of adhesive.
4. There will be no more than three (3) consecutive missing components in a tape.
5. A tape trailer, having at least three feed holes are provided after the last component in a tape.
6. Splices should not interfere with the sprocket feed holes.

REMARKS

- *1 Cumulative pitch error 1.0 mm/20 pitch
- *2 To be measured at bottom of clinch
- *3 At top of body
- *4 At top of body
- *5 t1 0.3 - 0.6 mm

Component Disposal Instructions

1. CDIL Semiconductor Devices are RoHS compliant, customers are requested to please dispose as per prevailing Environmental Legislation of their Country.
2. In Europe, please dispose as per EU Directive 2002/96/EC on Waste Electrical and Electronic Equipment (WEEE).

Customer Notes

**BC556, A, B,
BC557, A, B, C
BC558, A, B, C**

TO-92

Plastic Package

For Lead Free Parts, Device

**Part # will be Prefixed with
"T"**

Disclaimer

The product information and the selection guides facilitate selection of the CDIL's Semiconductor Device(s) best suited for application in your product(s) as per your requirement. It is recommended that you completely review our Data Sheet(s) so as to confirm that the Device(s) meet functionality parameters for your application. The information furnished in the Data Sheet and on the CDIL Web Site/CD are believed to be accurate and reliable. CDIL however, does not assume responsibility for inaccuracies or incomplete information. Furthermore, CDIL does not assume liability whatsoever, arising out of the application or use of any CDIL product; neither does it convey any license under its patent rights nor rights of others. These products are not designed for use in life saving/support appliances or systems. CDIL customers selling these products (either as individual Semiconductor Devices or incorporated in their end products), in any life saving/support appliances or systems or applications do so at their own risk and CDIL will not be responsible for any damages resulting from such sale(s).

CDIL strives for continuous improvement and reserves the right to change the specifications of its products without prior notice.



CDIL is a registered Trademark of
Continental Device India Limited

C-120 Naraina Industrial Area, New Delhi 110 028, India.

Telephone + 91-11-2579 6150, 5141 1112 Fax + 91-11-2579 5290, 5141 1119

email@cdil.com www.cdilsemi.com